

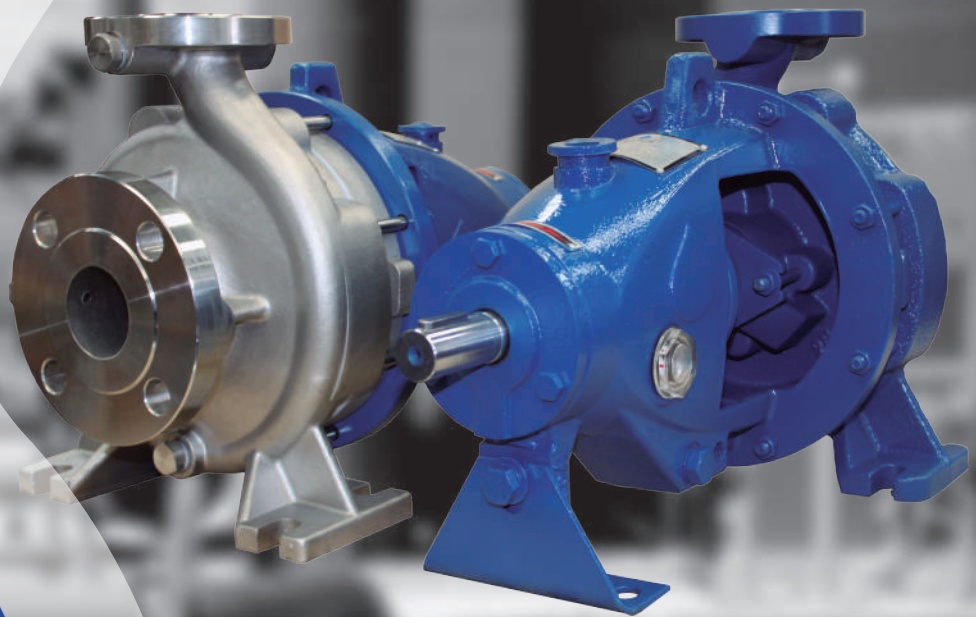

by **Beyond**  
Industrial



**BOMBAS  
CENTRÍFUGAS  
INDUSTRIALES  
DIN 24255**

**SERIE BA**



# SERIE BA - NORMAS BS / EN733 / DIN 24255

## Descripción

La serie entera de bombas centrífugas de succión final ha sido desarrollada bajo las normas europeas BS EN733 / DIN 24255 cumpliendo con las dimensiones y el desempeño.

Las bombas BA tienen aplicación en el manejo de líquidos limpios o ligeramente contenidos de sólidos con características similares al agua. Su diversidad de aplicaciones va desde plantas de producción industrial en general, minería, aire acondicionado, petróleo, sistemas contra incendio, riego, estaciones de bombeo, etc.

Por su diseño, se requieren únicamente 4 tipos de bastidor para 42 modelos básicos, que permiten la intercambiabilidad de partes con el consecuente ahorro en stock de repuestos. Su versatilidad permite una cobertura amplia de aplicación en la industria en general.



## Rango de operación

<b>Caudal (Q)</b>	Hasta 1100 m <sup>3</sup> /hr
<b>Cabeza (H)</b>	Hasta 150 m
<b>Velocidad</b>	Hasta 3500 rpm
<b>Temperatura</b>	105°C
<b>Presión de trabajo</b>	10 bar, opcional 16 bar

## Materiales

<b>Carcasa</b>	Fundición gris, hierro dúctil o acero inoxidable AISI 304 o 316
<b>Tapa de Carcasa</b>	Fundición gris, hierro dúctil o acero inoxidable AISI 304 o 316
<b>Impulsor</b>	Fundición gris estándar, opcional Bronce; o AISI 304 o 316
<b>Eje</b>	AISI 420 estándar, opcional AISI 304 o 316
<b>Cierre del eje</b>	<ul style="list-style-type: none"><li>• Sello mecánico, con ejecuciones especiales</li><li>• Prensa-estopa</li></ul>



# IDENTIFICACIÓN DE PARTES

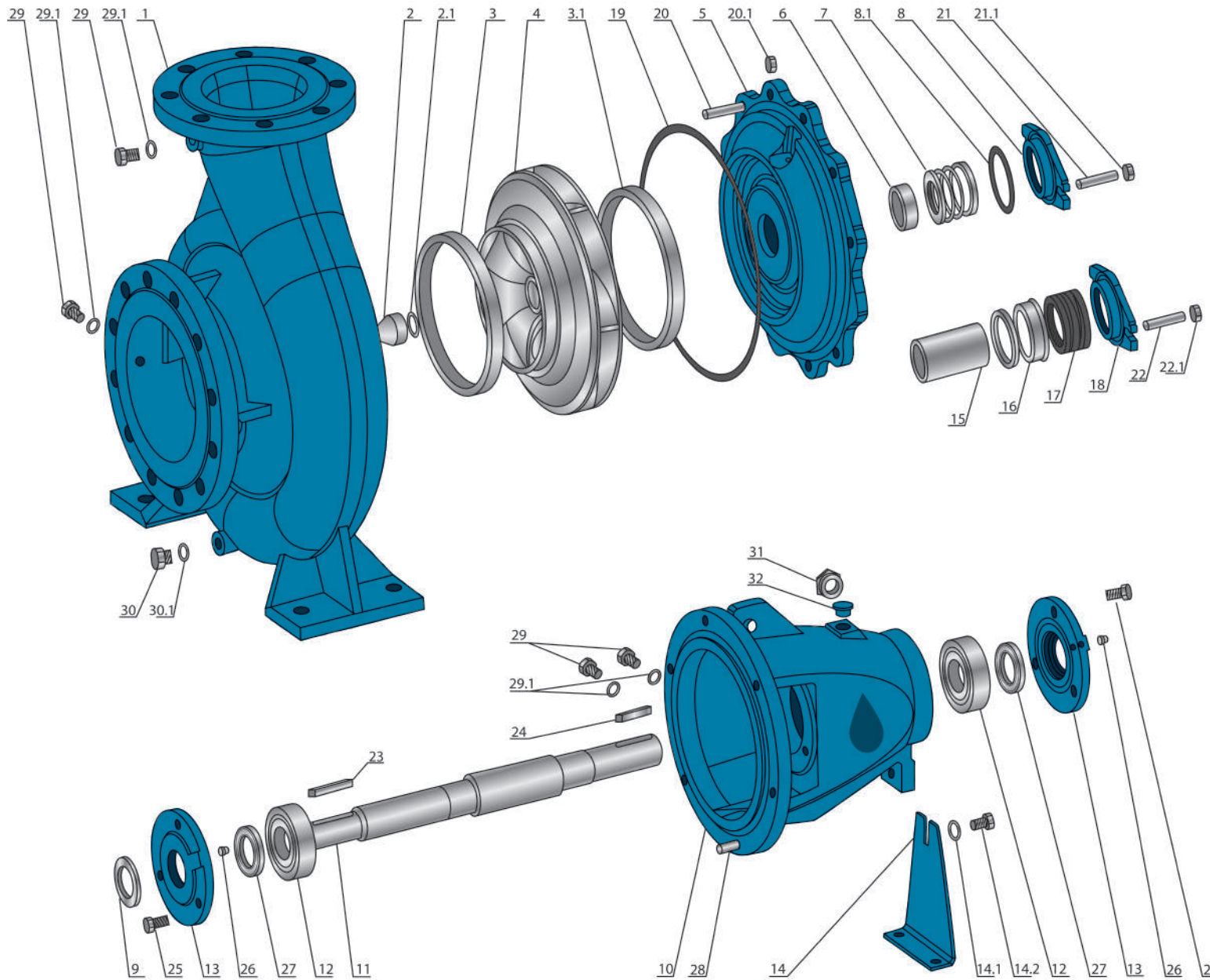

Código	Nombre de parte	Cantidad
1	Carcasa	1
2	Tuerca impulsor	1
2.1	Arandela de seguridad	1
3	Anillo de desgaste delantero	1
3.1	Anillo de desgaste trasero	1
4	Impulsor	1
5	Tapa de carcasa	1
6	Casquillo del eje	1
7	Sello mecánico	1
8	Tapa de sello	1
8.1	O'ring	1
9	Deflector	1
10	Bastidor	1
11	Eje	1
12	Rodamiento	2
13	Tapa de rodamiento	2
14	Pata de soporte	1
14.1	Arandela	1
14.2	Tornillo	1
15	Casquillo del eje P.E	1
16	Linterna	1
17	Cordón grafitado P.E	1 set
18	Casquete P.E	1
19	Empaque de carcasa	1
20	Espárrago	1 set
20.1	Tuerca	1 set
21	Espárrago	1 set
21.1	Tuerca	1 set
22	Espárrago	1 set
22.1	Tuerca	1 set
23	Cuña	1
24	Cuña	1
25	Tornillo	2 sets
26	Grasera	2
27	Retenedor	2
28	Espárrago	1 set
29	Tapón	1
29.1	O'ring	1
30	Tapón	1
30.1	Anillo de sello	1
31	Mirilla	1
32	Tapón del bastidor	1



# DIMENSIONES GENERALES SERIE BA

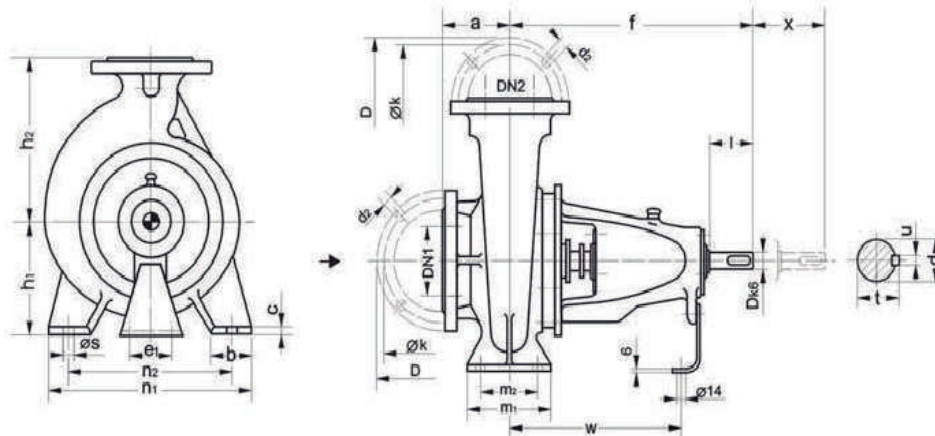

Modelo	Bastidor	D2	D1	a	f	h1	h2	b	c	n3	m2	n1	n2	m1	s	w	d	l	t	u	x
BA 32/13	25	1.1/4"	2"	80	360	112	140	50	14	100	70	190	140	100	14	267	24	50	27	8	4
BA 32/16	25A	1.1/4"	2"	80	360	132	160	50	14	100	70	240	190	100	14	267	24	50	27	8	4
BA 32/20	25	1.1/4"	2"	80	360	160	180	50	14	110	70	240	190	100	14	267	24	50	27	8	4
BA 32/26	25A	1.1/4"	2"	100	360	180	225	65	14	110	95	320	250	125	14	267	24	50	27	8	4
BA 40/13	25	1.1/2"	2.1/2"	80	360	112	140	50	14	100	70	210	160	100	14	267	24	50	27	8	4
BA 40/16	25A	1.1/2"	2.1/2"	80	360	132	160	50	14	100	70	240	190	100	14	267	24	50	27	8	4
BA 40/20	25	1.1/2"	2.1/2"	100	360	160	180	50	14	110	95	265	212	100	14	267	24	50	27	8	4
BA 40/26	25A	1.1/2"	2.1/2"	100	360	180	225	65	14	110	95	320	250	125	14	267	24	50	27	8	4
BA 40/32	35	1.1/2"	2.1/2"	125	470	200	250	65	14	110	95	345	280	125	14	342	32	80	35	10	4
BA 40/32H	35	1.1/2"	2.1/2"	125	470	200	250	65	14	110	95	345	280	125	14	342	32	80	35	10	4
BA 40/32G	45	1.1/2"	2.1/2"	125	526	200	250	65	14	100	95	345	280	125	14	367	42	110	45	12	4
BA 50/13	25	2"	2.1/2"	100	360	132	160	50	14	100	70	240	190	100	14	267	24	50	27	8	4
BA 50/16	25	2"	2.1/2"	100	360	160	180	50	14	110	70	265	212	100	14	267	24	50	27	8	4
BA 50/20	25	2"	2.1/2"	100	360	160	200	50	14	110	70	265	212	100	14	267	24	50	27	8	4
BA 50/26	25	2"	2.1/2"	100	360	180	225	65	14	110	95	320	250	125	14	267	24	50	27	8	4
BA 50/32	35	2"	2.1/2"	125	470	225	280	65	18	110	95	345	280	125	14	342	32	80	35	10	4
BA 50/32H	35	2"	2.1/2"	125	470	225	280	65	18	110	95	345	280	125	14	342	32	80	35	10	4
BA 50/32G	45	2"	2.1/2"	125	526	225	280	65	18	110	95	345	280	125	14	367	42	110	45	12	4
BA 65/13	25	2.1/2"	3"	100	360	160	180	65	14	110	95	280	212	125	14	267	24	50	27	8	4
BA 65/16	25	2.1/2"	3"	100	360	160	200	65	14	110	95	280	212	125	14	267	24	50	27	8	4
BA 65/20	25	2.1/2"	3"	100	360	180	225	65	14	110	35	320	250	125	14	267	24	50	27	8	4
BA 65/26	35	2.1/2"	3"	100	470	200	250	80	15	110	120	360	280	160	18	342	32	80	35	10	4
BA 65/32	35	2.1/2"	3"	125	470	225	280	80	18	110	120	400	315	160	18	342	32	80	35	10	4
BA 65/32H	35	2.1/2"	3"	125	470	225	280	80	18	110	120	400	315	160	18	342	32	80	35	10	4
BA 65/32G	45	2.1/2"	3"	125	525	225	280	80	18	110	120	400	315	160	18	367	42	110	45	12	4
BA 80/16	25	3"	4"	125	360	180	225	65	14	110	95	320	250	125	14	267	24	50	27	8	4
BA 80/20	35	3"	4"	125	470	180	250	65	15	110	95	345	280	125	14	342	32	80	35	10	4
BA 80/26	35	3"	4"	125	470	200	280	80	15	110	120	400	315	160	18	342	32	80	35	10	4
BA 80/32	35	3"	4"	125	470	250	315	80	16	110	120	400	315	160	18	342	32	80	35	10	4
BA 80/32H	35	3"	4"	125	470	250	315	80	16	110	120	400	315	160	18	342	32	80	35	10	4
BA 80/32G	45	3"	4"	125	526	250	315	80	16	110	120	400	315	160	18	367	42	110	45	12	4
BA 80/40	45	3"	4"	125	530	280	355	83	18	110	120	440	340	160	18	370	42	110	45	12	4
BA 100/16	35	4"	5"	125	470	200	250	80	15	110	120	360	280	160	18	342	32	80	35	10	4
BA 100/20	35	4"	5"	125	470	200	280	80	16	110	120	360	280	160	18	342	32	80	35	10	4
BA 100/26	35	4"	5"	140	470	225	280	80	16	110	120	400	315	160	18	342	32	80	35	10	4
BA 100/32	35	4"	5"	140	470	250	315	80	16	110	120	400	315	160	18	342	32	80	35	10	4
BA 100/40	45	4"	5"	140	530	280	355	100	20	110	150	500	400	200	23	370	42	110	45	12	4
BA 125/20	35	5"	6"	140	470	250	315	80	16	110	120	400	315	160	18	342	32	80	35	10	4
BA 125/26	35	5"	6"	140	470	250	355	80	16	110	120	400	315	160	18	342	32	80	35	10	4
BA 125/32	45	5"	6"	140	530	280	355	100	18	110	150	500	400	200	23	370	42	110	45	12	4
BA 125/40	45	5"	6"	140	530	315	400	100	18	110	150	500	400	200	23	370	42	110	45	12	4
BA 150/20	35	6"	8"	160	500	280	400	100	18	110	150	400	315	200	23	342	32	80	35	10	4
BA 150/26	45	6"	8"	160	530	250	355	100	18	110	150	450	350	200	23	370	42	110	45	12	4
BA 150/32	45	6"	8"	160	530	280	400	100	18	110	150	550	450	200	23	370	42	110	45	12	4
BA 150/40	45	6"	8"	160	530	315	450	100	18	110	150	550	450	200	23	370	42	110	45	12	4
BA 200/26	45	8"	10"	180	53	315	450	100	20	110	150	550	450	200	28	370	42	110	45	12	4
BA 200/32	55	8"	10"	180	670	315	480	120	20	110	170	600	480	220	28	505	48	110	51	14	4
BA 200/40	55	8"	10"	180	670	335	480	120	20	110	170	600	480	220	28	505	48	110	51	14	4
BA 250/32	55	12"	10"	220	691	355	520	150	26	110	200	660	510	250	28	525	48	110	51	14	4
BA 250/40	55	12"	10"	220	682	400	560	150	26	110	200	660	510	250	28	516	48	110	51	14	4

\*\*\*SUJETO A CAMBIOS SIN PREVIO AVISO\*\*\*



# INTERCAMBIABILIDAD DE PARTES SERIE BA

MODELO	SOPORTE	TAPAS SOPORTE	EJE	CASQUILLO		PRENSA-ESTOPA	CASQUETE P.E	BRIDA SELLO	TUERCA	TAPA DE CARCASA	ANILLOS DE DESGASTE		CARCASA	IMPULSOR		
				S.M	P.E						ANILLO FRONTAL	ANILLO TRASERO				
32/13	25									1	70x 10		32/13	32/13		
40/13											80x 12		40/13	40/13		
50/13											95x 10		50/13	50/13		
65/13											115x 12		65/13	65/13		
32/16	25A	25	25	25	25	25	25	25	25	M16X1.5	70x 10		32/16	32/16		
40/16											80x 12		40/16	40/16		
50/16											95x 10		50/16	50/16		
65/16											115x 12		65/16	65/16		
80/16	25										130x 16		80/16	80/16		
32/20											80x 12		32/20	32/20		
40/20											80x 12		40/20	40/20		
50/20											95x 10		50/20	50/20		
65/20	25A										115x 12		65/20	65/20		
32/26											80x 12		32/26	32/26		
40/26											95x 10		40/26	40/26		
50/26											115x 12		50/26	50/26		
80/20	35	35	35	35	35	35	35	35	35	M24	130x 16		80/20	80/20		
100/20											160x 15		100/20	100/20		
65/26											115x 12		65/26	65/26		
80/26											130x 16		80/26	80/26		
100/26											160x 15		100/26	100/26		
125/26											180x 20		125/26	125/26		
40/32											95x 10		40/32	40/32		
50/32											115x 12		50/32	50/32		
65/32											130x 16		65/32	65/32		
80/32											140x 15		80/32	80/32		
100/32	160x 15		100/32	100/32												
125/32	45	45	45	45	45	45	45	45	45	M30X2	180x 20		125/32	125/32		
150/32											200x 20		150/32	150/32		
80/40											140x 15		80/40	80/40		
100/40											160x 15		100/40	100/40		
125/40											180x 20		125/40	125/40		
150/40											200x 20		150/40	150/40		
40/32G	45	45	35G	35G	35G	45	45	45	45	M24	11G110		40/32	40/32		
50/32G											11G130		50/32	50/32		
65/32G											8G		65/32	65/32		
80/32G											140X16		80/32	80/32		
150/26			45	45	45					M30X2	13	200X20	200X20	150/26	150/26	
125/20	35	35	35	35	35	35	35	35	35	M24	5	180X20		125/20	125/20	
150/20											200X214		150/20	150/20		
65/20G											25G	35G	65/20G		65/20	65/20
50/26G													50/26G		50/26	50/26
100/16			35	35	35					M24	5	160X15		100/16	100/16	
200/26	45	45	45	45	45	45	45	45	45	M30	9	235X18	200X20	200/26	200/26	
200/32	55	55	55	55	55	55	55	55	55	M36	14	250X18	250X18	200/32	200/32	
200/40											15	235X18	235X18	200/40	200/40	
250/32											14	260X20	250X18	250/32	250/32	
250/40											15	270X18	235X18	250/40	250/40	



# CURVAS 3500rpm SERIE BA

3500rpm

Q (US.G.P.M)

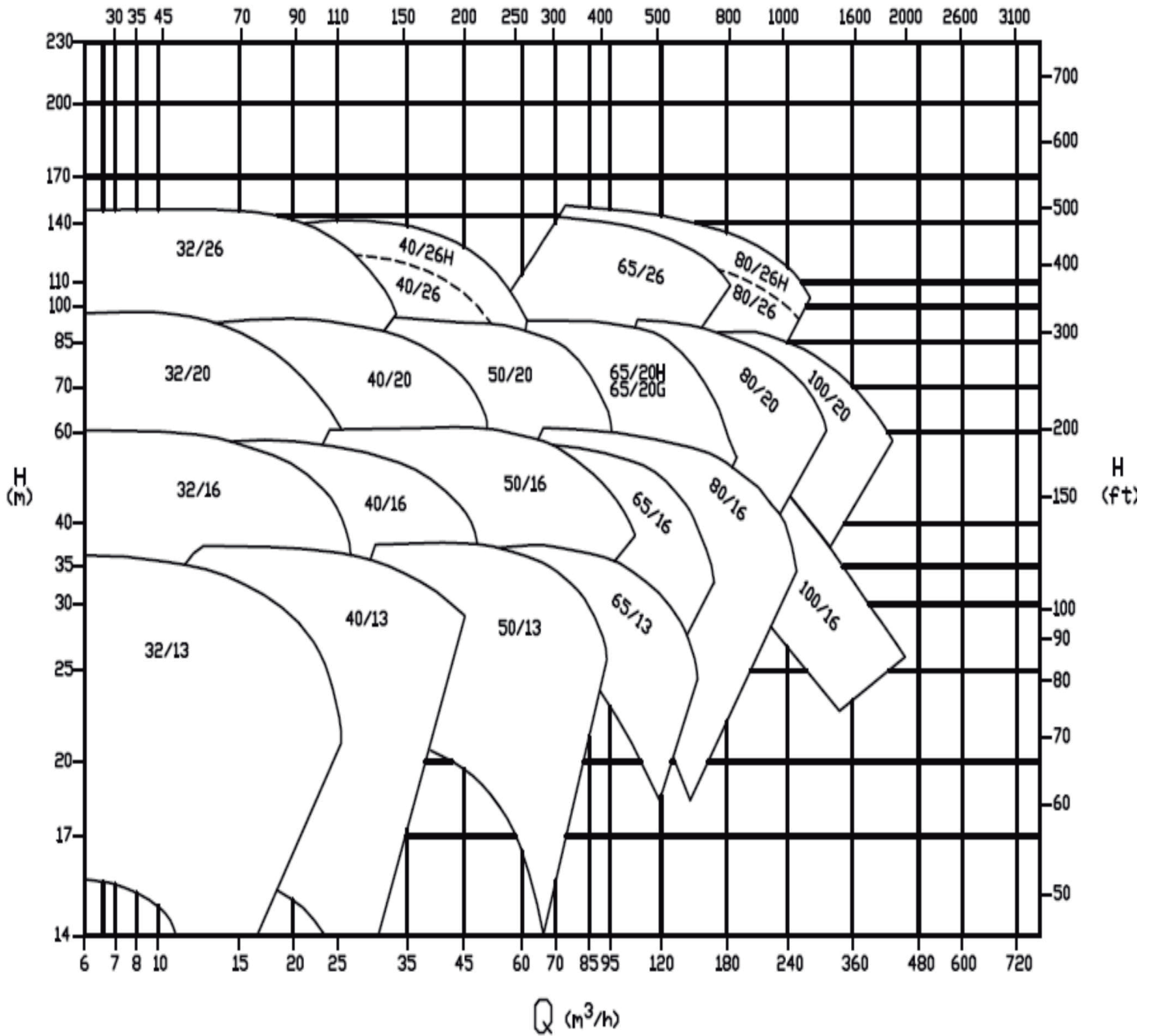



# CURVAS 1750rpm SERIE BA

1750rpm

Q (US.G.P.M)

